



FLAMTEC

**Gas Burner
Monoblock
Gama
Mechanical
Modulation
Mechanic Cam
Domestic
Burner Series
120-2100 kw/h**

**A Leading
Manufacturer of
Innovative
Combustion
Solutions**

We simply technology for industrial solutions



Flamtec is an innovative burner manufacturer based in Barcelona, Spain. We specialized on combustion solutions. Working with the most experienced team, Flamtec has a unique place in the burner world.

We produce burner according to sustainable environmental policies. More environmentally friendly and economical burner designs are our investment in our future .

The right choice of burner is not a sale technique, it is a sale principle for us. That's why, we propose always the most beneficial combustion solution for you.

Main Features

- » It can be used with natural gas, propane, biogas etc.
- » Suitable for water-tube boiler, ovens, dryer, diathermic oil generators etc.
- » Flame can be adjustable according to firing chamber
- » Combustion head, fan, control panel, gas train can be selected according to specific circumstances.
- » Modulation ration is 1/5 and it is really advantageous according to its competitors..
- » For multiple burner-boiler installation, special type of sensor is used.
- » Offers the possibility to heat and use of combustion air and provides an energy saving by increasing the combustion performance through the air economizer using in the system.
- » Provides the flame control between minimum and maximum capacities.
- » Has a feature of compatible running in different firing chambers.
- » Minimizes the amount of the gas emission especially nitrous oxide (NOx) gas by achieving an optimum air fuel mixture thanks to the special design mixer group.
- » By way of the compact dimensions provides an easy mounting and running conditions in narrow areas.
- » Due to the high-pressured fan, it has a feature of working productive opposing the flue and high firing chamber.
- » Easy to assemble the gas train to the burner
- » Standard protection is IP 54 mechanic parts.
- » If it is requested, IP 65 is possible as protection standard.
- » Internal or external Flue Gas Recirculation is available to decrease NOx emissions
- » All wiring, burner management system and electrical supply are included.

Conformity with directives as below

- 89/336 (2004/108) EEC
- 73/23/EEC
- 98/37/EEC
- 90/396/EEC
- EN 676

OPTIONS

- » O2 Trim control to provide extra efficiency.
- » Dungs VPS 504 Gas Leakage Control
- » CO Trim control to promote sensitive control system
- » Variable Speed Drive (Inverter) to prolong the product life
- » IP 65 Protection Class for special project
- » Premix head can be selected as Low NOx Burner
- » Internal or External Flue Gas Recirculation for low emission rules
- » Simultaneous firing
- » Soundproof fan



Endless Possibilities

01 Worldwide direct and immediately service



02 Optimized and Customized efficient technological solutions

03 Maximized efficiency
Ultra cost-saving

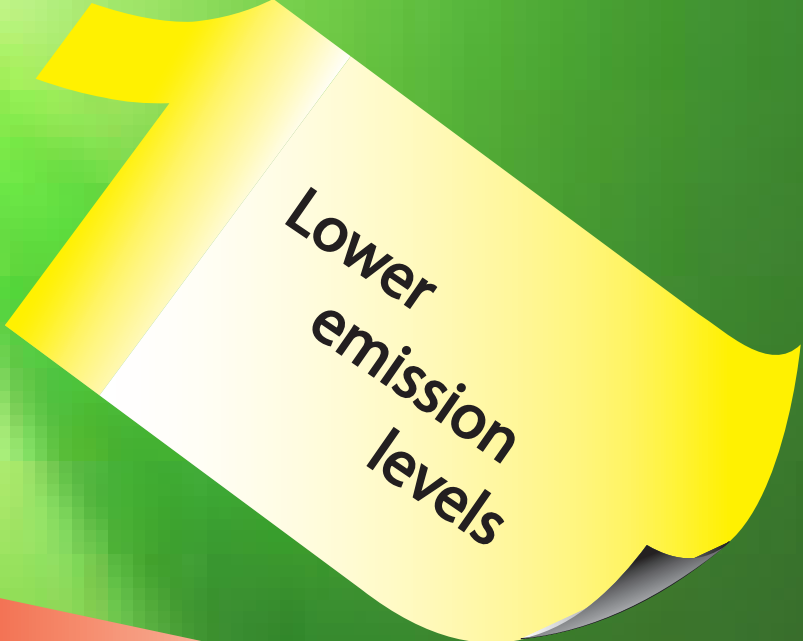

Lower
emission
levels



Improve
operating
efficiency



Easy serviceability
and maintenance

Technical Features

Type	Capacity						Power Supply	Motor Kw	GAS INPUT PRESSURE mbar
	Kw min-max		kcal/h min-max		m3/h min-max				
SC 1.1 GM	18	120	15.480	103.200	1,88	7,82	1N - 50 Hz 230V	0,15	100-300
SC 1.2 GM	50	180	43.000	154.800	5,21	18,76	1N - 50 Hz 230V	0,15	100-300
SC 2.1 GM	80	280	68.800	240.800	8,34	29,19	1N - 50 Hz 230V	0,25	100-300
SC 2.2 GM	100	360	86.000	309.600	10,42	37,53	1N - 50 Hz 230V	0,25	100-300
SC 3.1 GM	110	500	94.600	430.000	11,47	52,12	1N - 50 Hz 230V	0,37	100-300
SC 3.2 GM	130	650	111.800	559.000	13,55	67,76	1N - 50 Hz 230V	0,37	100-300
SC 5.1 GM	200	750	172.000	645.000	20,85	78,18	1N - 50 Hz 380V	0,75	100-300
SC 5.2 GM	260	950	223.600	817.000	27,1	99,03	3N - 50 Hz 380V	1,5	100-300
SC 8.1 GM	330	1150	283.800	989.000	34,4	119,88	3N - 50 Hz 380V	1,5	100-300
SC 8.2 GM	430	1600	369.800	1.376.000	44,82	166,79	3N - 50 Hz 380V	2,2	100-300
SC 8.3 GM	580	2100	498.000	1.806.000	60,46	218,91	3N - 50 Hz 380V	3	100-300

Heating values of gaseous fuels

Fuel	Density Kg/m ³	LOWER HEATING VALUE			
		MJ/kg	MJ/m ³ n	Kcal/m ³ n	Kw/m ³ n
G20 Nat gas	-	-	35.58	8500	9.68
Propano	2.02	45.98	92.88	22188	25.80
Butano	2.71	45.70	123.84	29585	34.40

Conversion of calorific values

$$1 \text{ kcal/kg} = 4.186 \text{ kJ/kg}$$

$$1 \text{ kWh/kg} = 3600 \text{ kJ/kg}$$

$$1 \text{ kcal/kg} = 0.001163 \text{ kWh/kg}$$

Type	Protection Level	Ignition Transformer	Modulation Ratio
SC 1.1 GM	IP 40	2X7,5 kW	1/7
SC 1.2 GM	IP 40	2x7,5 kW	1/4
SC 2.1 GM	IP 40	2x7,5 kW	1/4
SC 2.2 GM	IP 40	2X7,5 kW	1/4
SC 3.1 GM	IP 40	2X7,5 kW	1/5
SC 3.2 GM	IP 40	2x7,5 kW	1/5
SC 5.1 GM	IP 40	2x7,5 kW	1/4
SC 5.2 GM	IP 40	2x7,5 kW	1/4
SC 8.1 GM	IP 40	2X7,5 kW	1/4
SC 8.2 GM	IP 40	2x7,5 kW	1/4
SC 8.3 GM	IP 40	2x7,5 kW	1/4

Did You Know?

Standard air density
1.293 Kg/m³ refers to 0°C
and 1013 mbar

Reference conditions:
Air Temperature 20 °C
Pressure 1013.5 mbar
Altitude 0m a.s.l

Dimensions

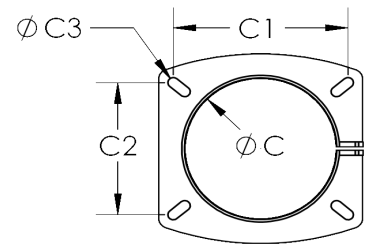
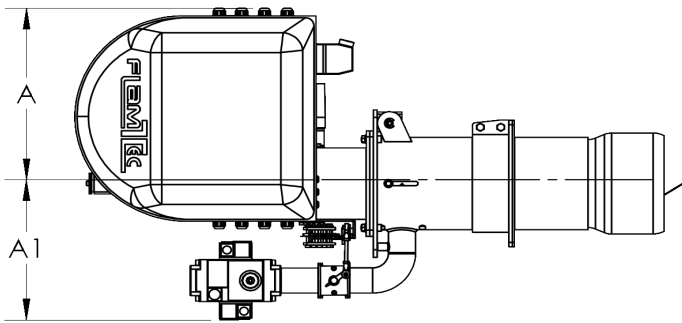
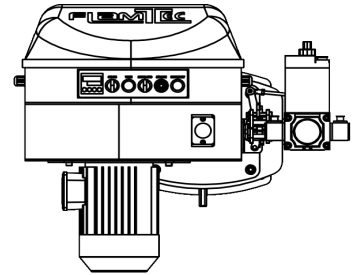
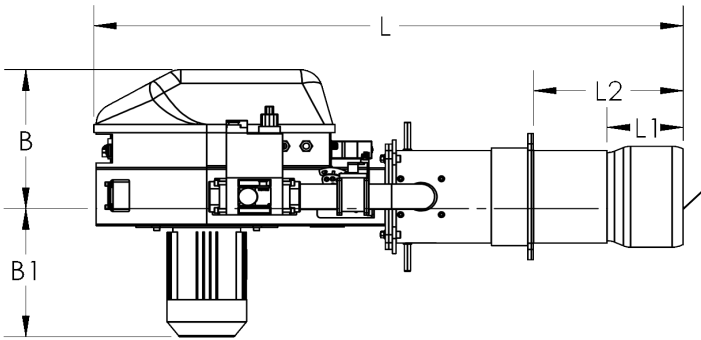

	A	A1	B	B1	ØC	C1	C2	ØC3	L	L1	L2
SC 1.1 GM	220	235	235	170	90	110	104	M6	620	77,5	120
SC 1.2 GM	220	235	235	170	90	110	104	M6	620	77,5	120
SC 2.1 GM	220	250	235	170	114	130	125	M8	660	110	190
SC 2.2 GM	250	320	290	185	114	130	125	M8	735	110	190
SC 3.1 GM	340	320	320	250	140	155	142	M12	1070	170	390
SC 3.2 GM	340	320	320	250	140	160	150	M12	1070	170	380
SC 5.1 GM	380	390	300	280	170	200	170	M12	1160	180	380
SC 5.2 GM	380	390	300	310	170	200	170	M12	1180	180	380
SC 8.1 GM	420	390	310	310	170	200	170	M12	1230	180	380
SC 8.2 GM	420	390	310	330	220	240	190	M14	1250	270	480
SC 8.3 GM	420	390	310	360	220	240	190	M14	1250	270	480

Capacitive Diagrams

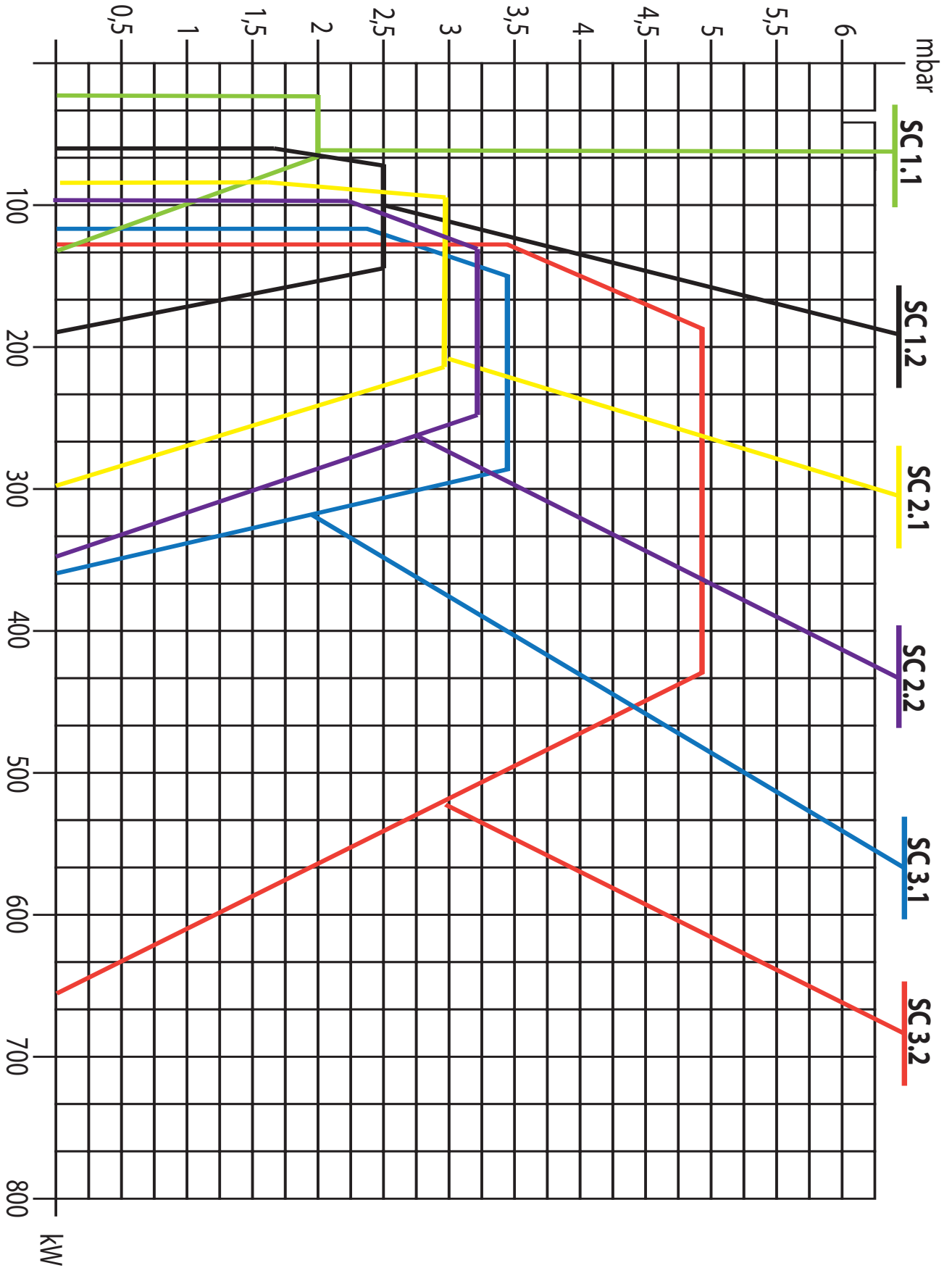

Capacitive Diagrams

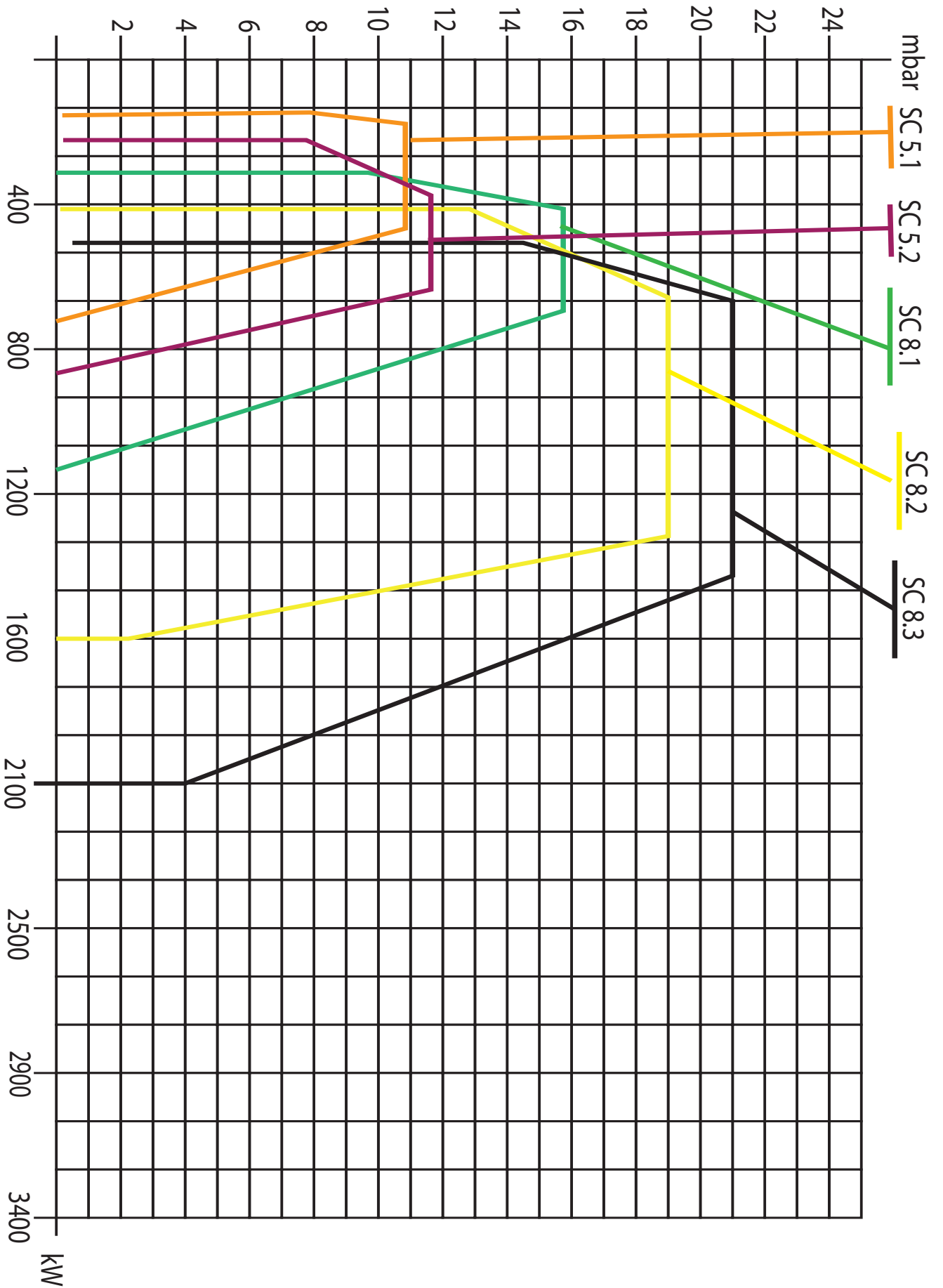

01 ▶

Easy maintenance easy access to the nozzle, scanner and the head of the burner without separating the burner from the fuel or power line.

◀ 02

Digital solution for efficiency and safety brings easiness and simplicity.

The most modern designs
are the investment on
our future. Compact and
aesthetic desings satisfy
elaborative customers.

◀ 04

03 ▶

Our burner works
quietly and provide
a tranquil athmosphere
for users.

Flame Diameter (Gas)

FLAME DIAMETER-GAS

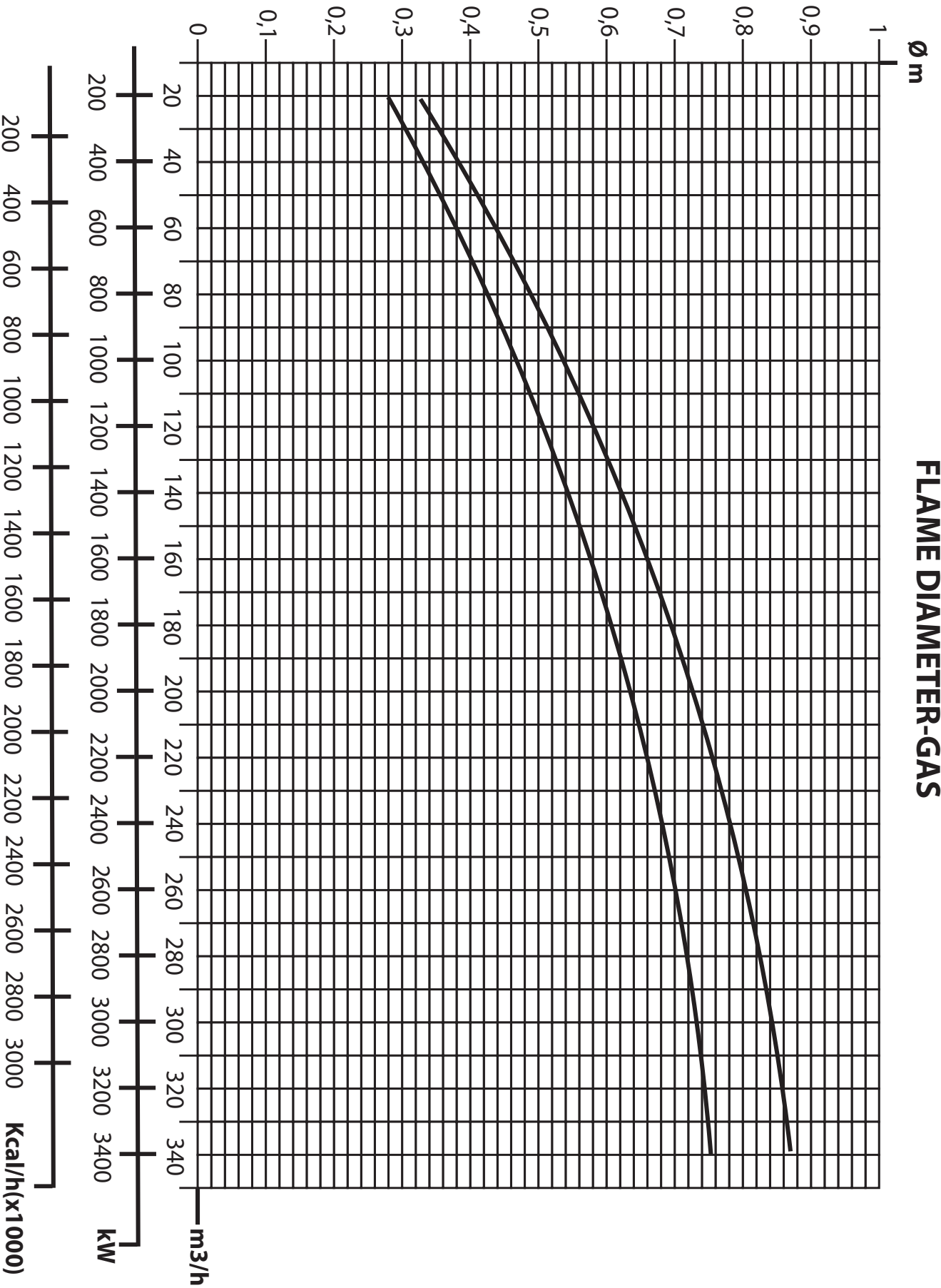

Flame Length (Gas)

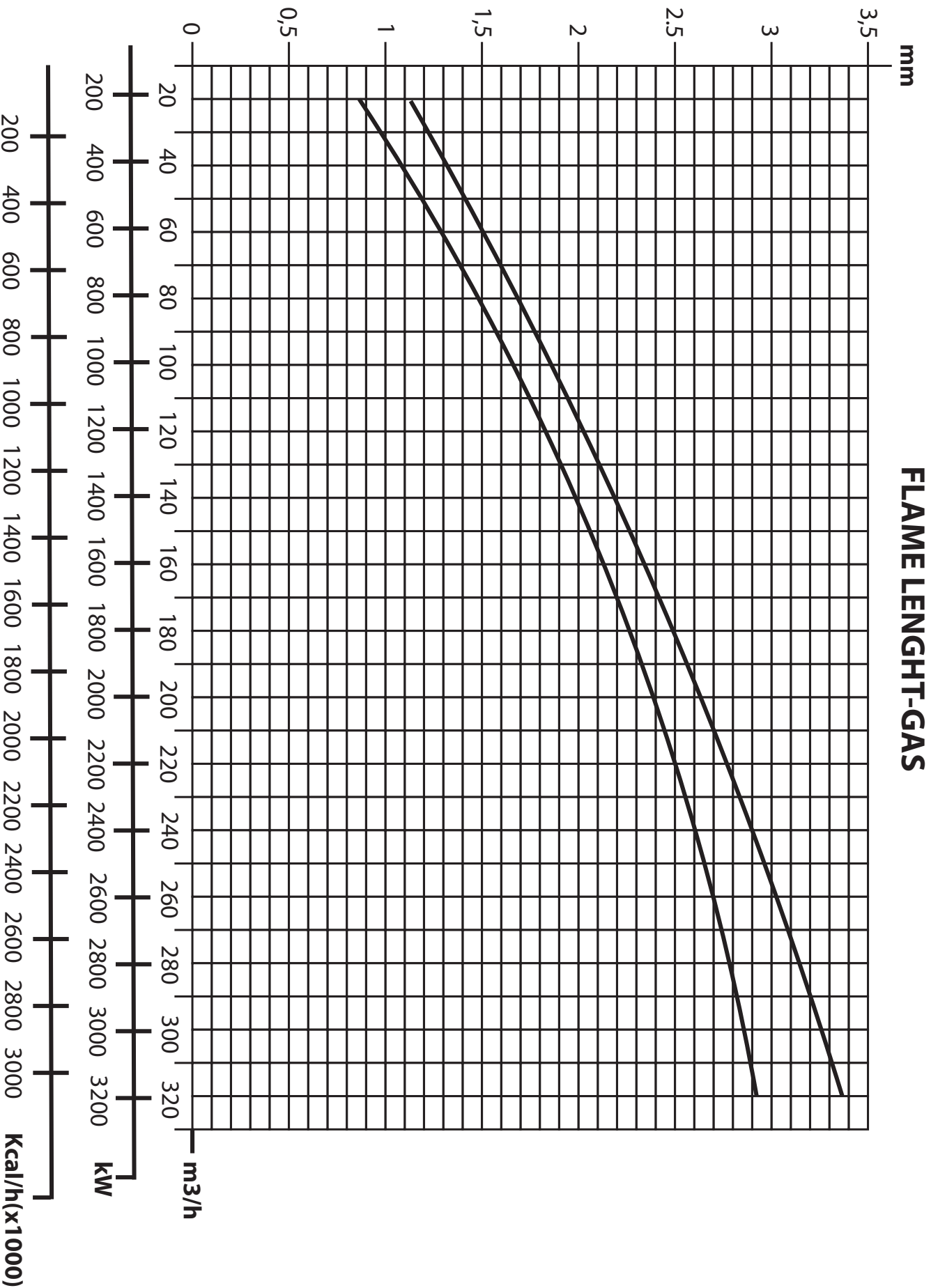

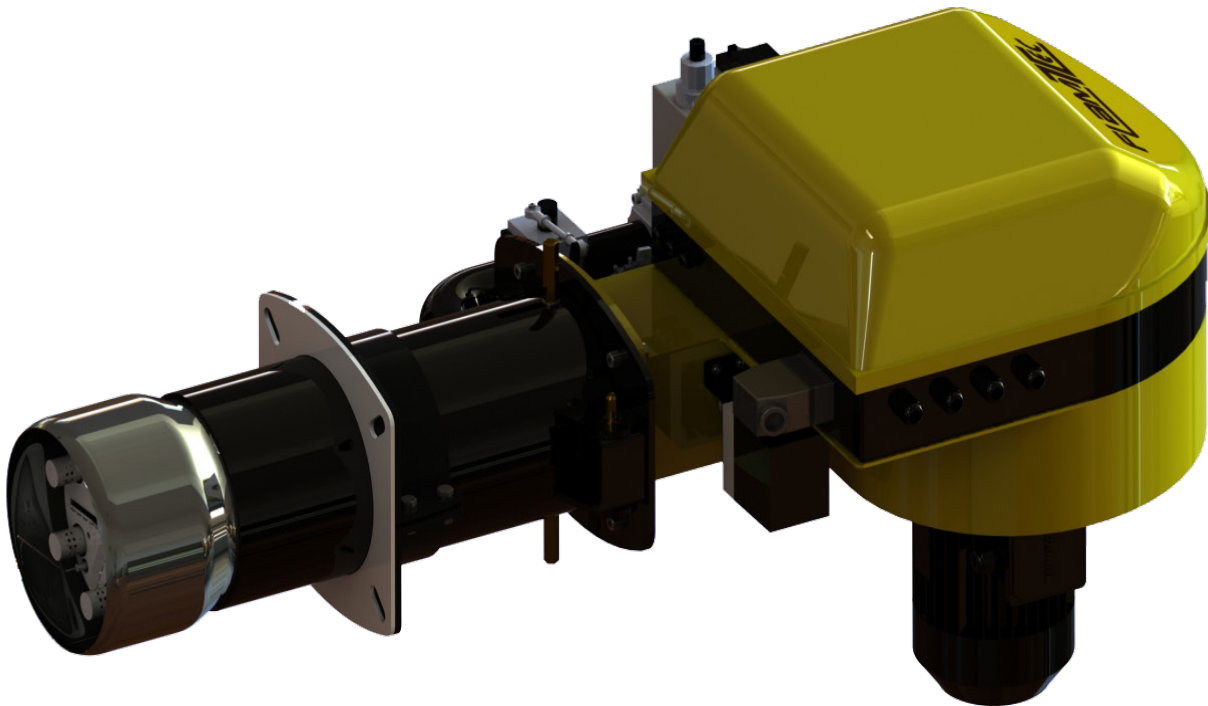
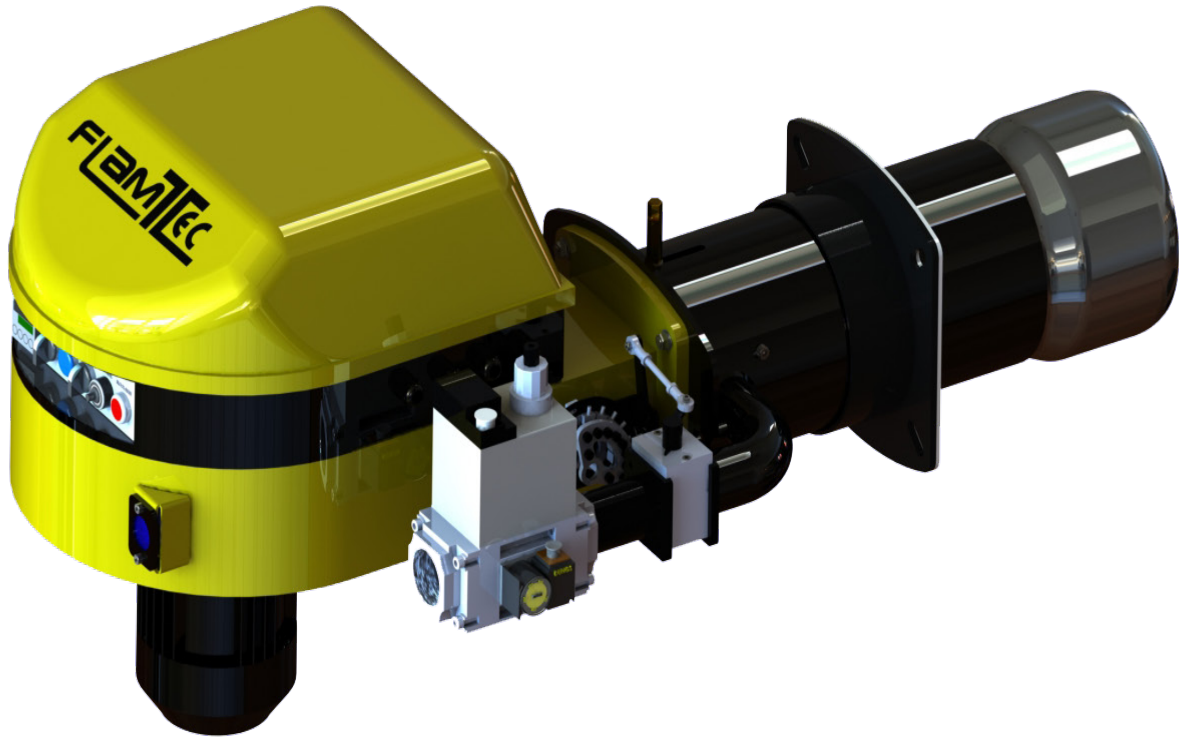

Flame Specifications

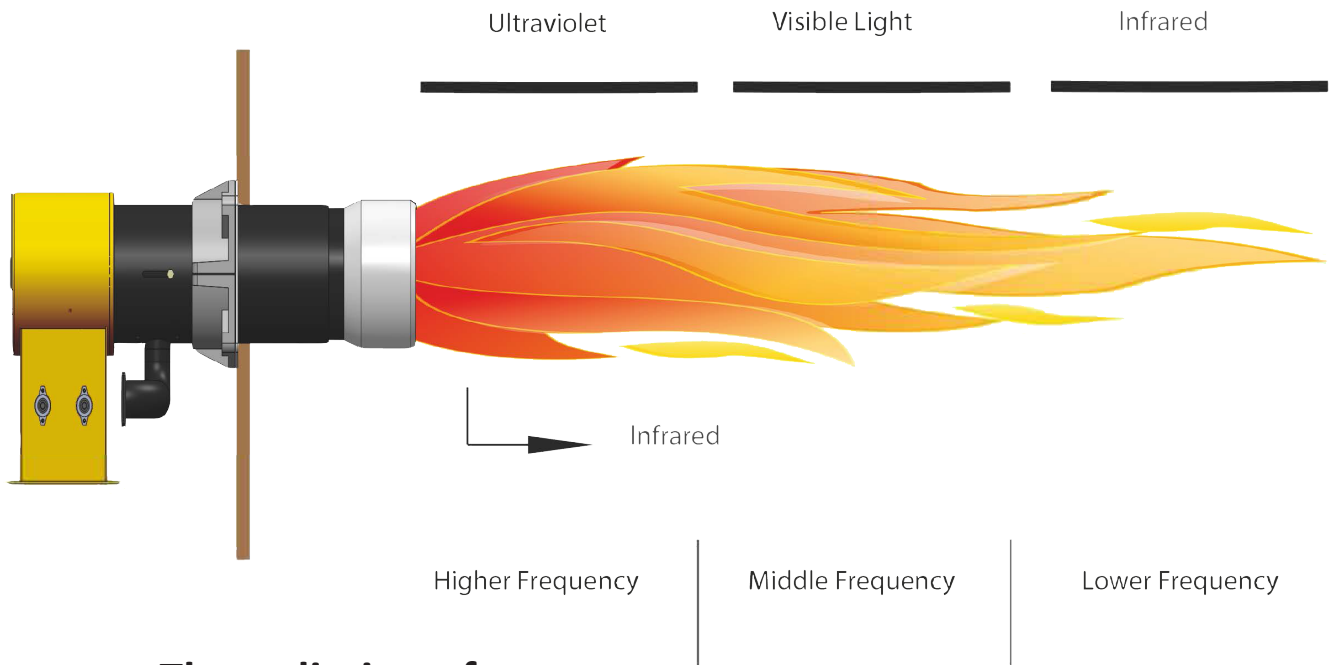

The radiation of rays

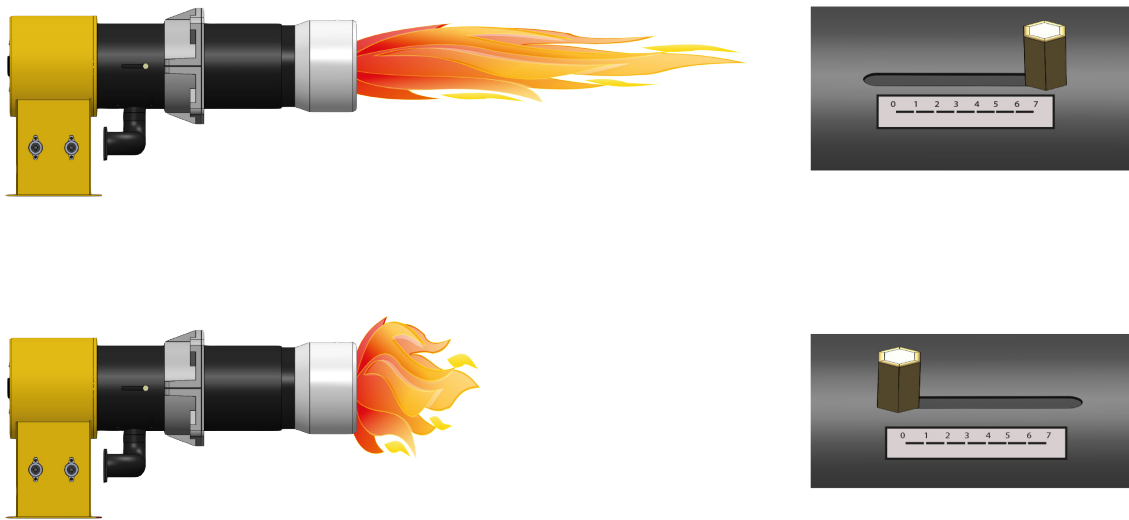

The arrangement of the shape of the flame

1 No need to additional control

2 Less workforce

3 Easy commissioning

4 Easy maintenance

Low maintenance



High reliability



Maximum flexibility
for
customized solutions

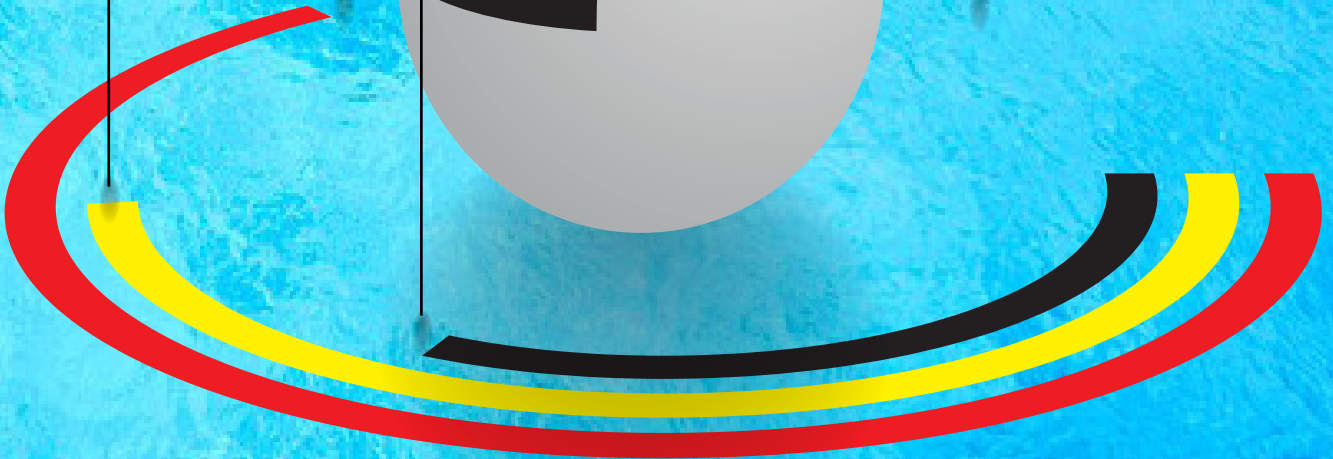

Gas Trains

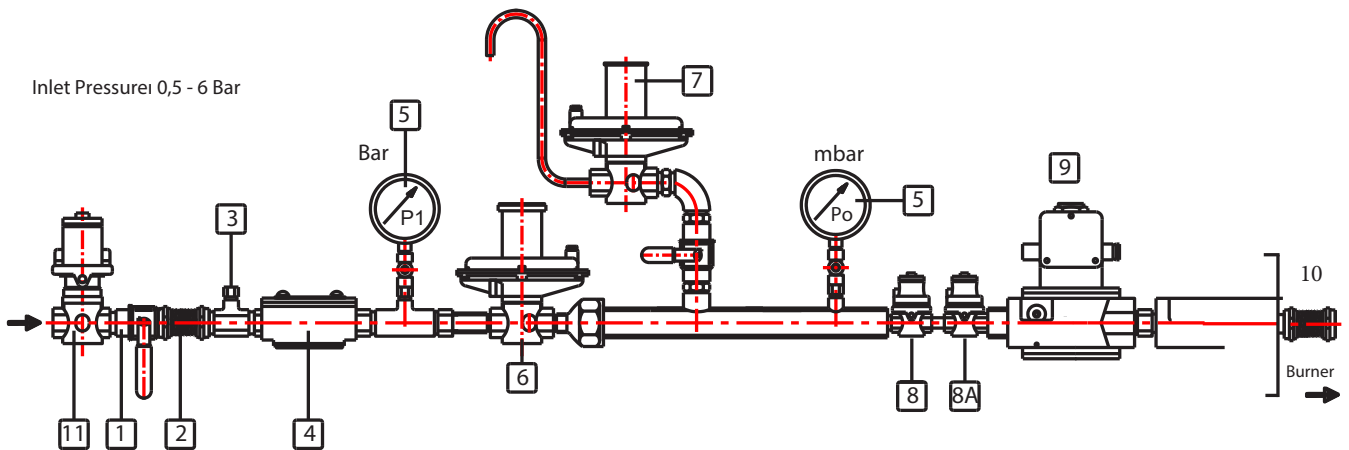

Operating gas pinlet pressure

150 - 300 mbar

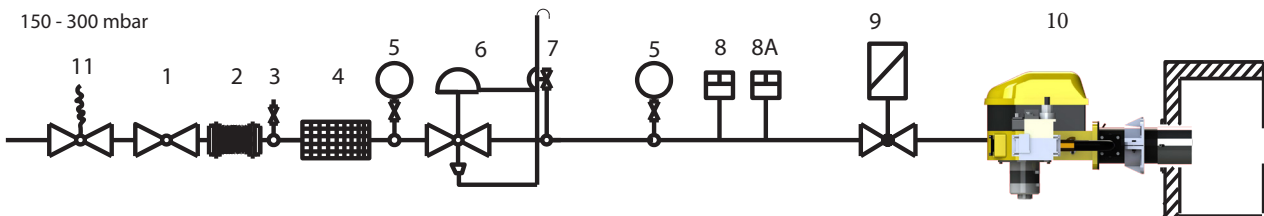

1-Ball Valve

2-Compensator

3-Testing nipple

4-Gas filter

5-Monometer (with tap)

6-Gas Pressure regulator

7-Relief Valve

8-MIN Gas pressure switch

8A-MAX.Gas pressure switch

9-Multiblock valve

10-Burner

11-Firing valve

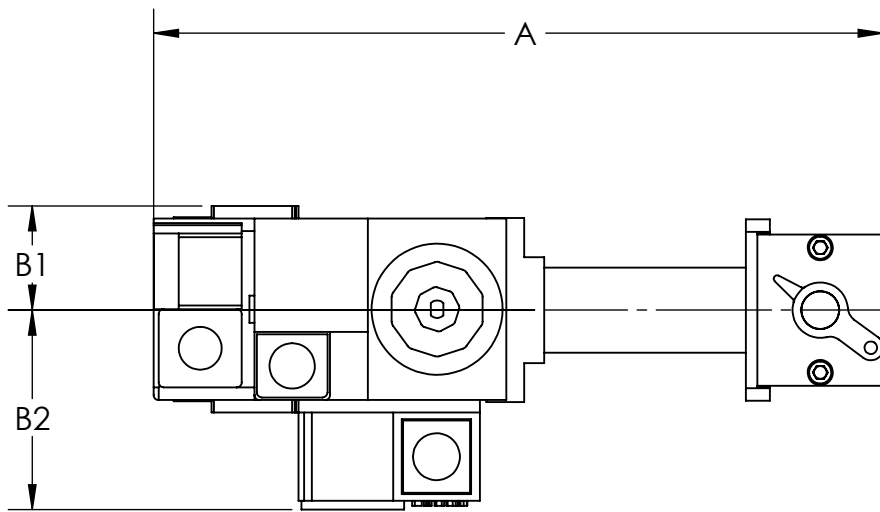
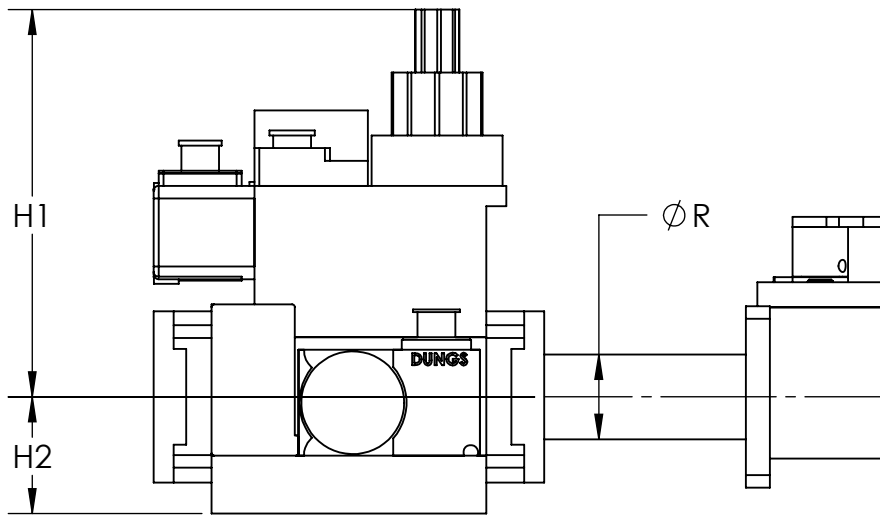

	$\varnothing R$	H1	H2	A	B1	B2
SC 1.1 GZ	27	215	50	250	40	85
SC 1.2 GZ	27	215	50	250	40	85
SC 2.1 GZ	27	215	50	250	40	85
SC 2.2 GZ	27	215	50	250	40	85
SC 3.1 GZ	34	160	50	280	40	85
SC 3.2 GZ	34	160	50	280	40	85
SC 5.1 GZ	34	160	50	280	40	85
SC 5.2 GZ	34	160	50	280	40	85
SC 8.1 GZ	48	180	50	360	95	95
SC 8.2 GZ	60	180	50	360	95	95
SC 8.3 GZ	60	180	50	360	95	95

Packing

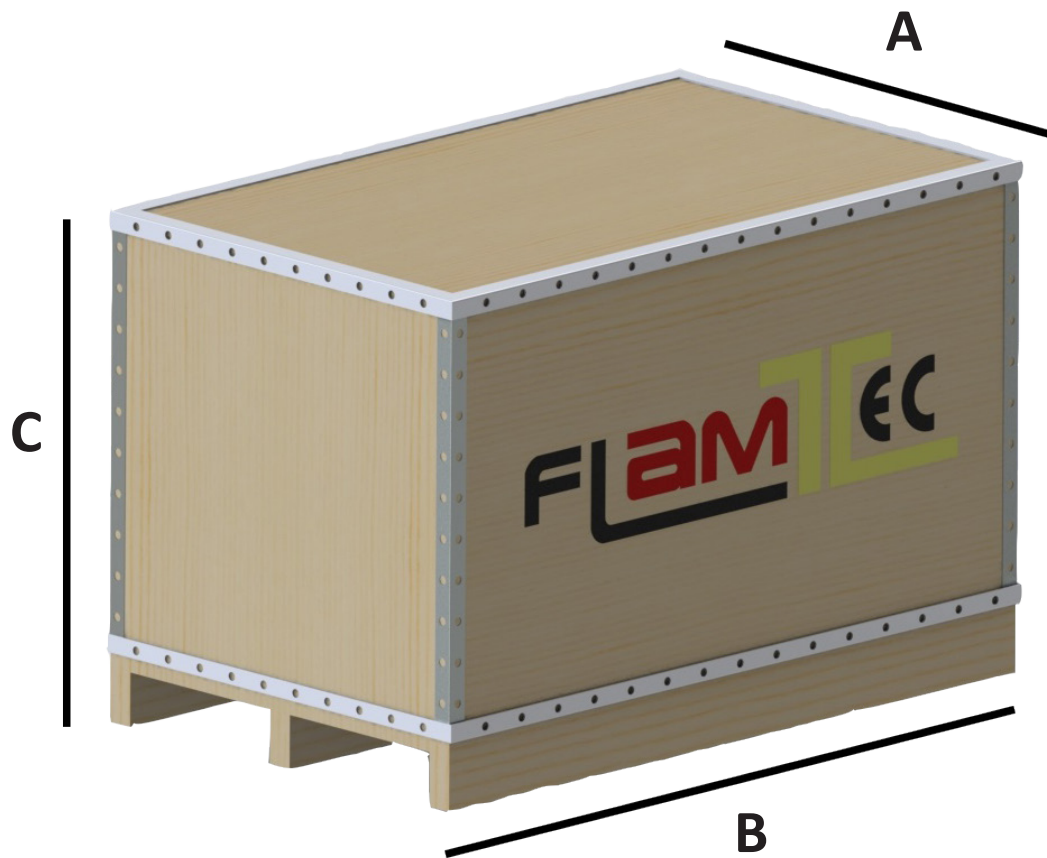

	Lenght(a)	Width(b)	Height(c)	Weight
SC 1.1 GM	61 cm	78 cm	56 cm	45 kg
SC 1.2 GM	61 cm	68 cm	56 cm	45 kg
SC 2.1 GM	63 cm	82 cm	56 sm	50 kg
SC 2.2 GM	73 cm	90 cm	63 cm	50 kg
SC 3.1 GM	81 cm	122 cm	70 cm	55 kg
SC 3.2 GM	81 cm	122 cm	72 cm	60 kg
SC 5.1 GM	93 cm	131 cm	75 cm	80 kg
SC 5.2 GM	96 cm	135 cm	77 cm	90 kg
SC 8.1 GM	96 cm	138 cm	80 cm	125 kg
SC 8.2 GM	96 cm	140 cm	80 cm	140 kg
SC 8.3 GM	96 cm	140 cm	85 cm	150 kg

Technical Specifications

	SC 1.1 GM	SC 1.2 GM	SC 2.1 GM	SC 2.2 GM	SC 3.1 GM	SC 3.2 GM	SC 5.1 GM	SC 5.2 GM	SC 8.1 GM	SC 8.2 GM	SC 8.3 GM
Structural steel (ST-37)plate body	•	•	•	•	•	•	•	•	•	•	•
Upper cover	•	•	•	•	•	•	•	•	•	•	•
Suitable case for high temperature	opt	opt	opt	opt	opt	opt	opt	opt	opt	opt	opt
Combustion head made from stainless stell withstand of 1150 °C	•	•	•	•	•	•	•	•	•	•	•
Gas filter	opt	opt	opt	opt	opt	opt	opt	opt	opt	opt	opt
Flame screening window	•	•	•	•	•	•	•	•	•	•	•
Ionisotion flame detector	opt	opt	opt	opt	opt	opt	opt	opt	opt	opt	opt
Protection Level for mechanic	IP 54	IP 54	IP 54	IP 54	IP 54	IP 54	IP 54	IP 54	IP 54	IP 54	IP 54
Protection Level for electric	IP 40	IP 40	IP 40	IP 40	IP 40	IP 40	IP 40	IP 40	IP 40	IP 40	IP 40
Air damper servomotors	•	•	•	•	•	•	•	•	•	•	•
Adjustable gas nozzles	4	4	4	4	4	4	4	4	4	4	4
Burner flange gasket	•	•	•	•	•	•	•	•	•	•	•
Instruction manual	•	•	•	•	•	•	•	•	•	•	•
On-Off Button	•	•	•	•	•	•	•	•	•	•	•
Work Lamp	-	-	•	•	•	•	•	•	•	•	•
Block Reset	•	•	•	•	•	•	•	•	•	•	•
Gas pipe	1"	1"	1"	1"	1"	1"	1"	1"	2"	2"	2"
Gasket	•	•	•	•	•	•	•	•	•	•	•
Nozzle holder	•	•	•	•	•	•	•	•	•	•	•
Turbulator	•	•	•	•	•	•	•	•	•	•	•
Gas Nozzle	4	4	4	4	4	4	6	6	6	6	6
Dungs LGW 3A 2 Air Pressure Switch	•	•	•	•	•	•	•	•	•	•	•
2x7,5 kw Transformer	•	•	•	•	•	•	•	•	•	•	•
Dungs GW 150 A5 Min Gas Pressure Switch	•	•	•	•	•	•	•	•	•	•	•
Dungs GW 500 A5 Max Gas Pressure Switch	•	•	•	•	•	•	•	•	•	•	•
Dungs VPS 504	opt	opt	opt	opt	opt	opt	opt	opt	opt	opt	opt
Siemens LFL Controller	•	•	•	•	•	•	•	•	•	•	•
Bearing	2	2	2	2	2	2	2	2	2	2	2
Cable Tube	•	•	•	•	•	•	•	•	•	•	•
Ignition electrode	•	•	•	•	•	•	•	•	•	•	•
Siemens SQM 31-401A2700	•	•	•	•	•	•	•	•	•	•	•
Flam Valve	•	•	•	•	•	•	•	•	•	•	•
Electric Motor	•	•	•	•	•	•	•	•	•	•	•
Fan	•	•	•	•	•	•	•	•	•	•	•
Pressure Transmitter	opt	opt	opt	opt	opt	opt	opt	opt	opt	opt	opt
PT-100 Heat probe	opt	opt	opt	opt	opt	opt	opt	opt	opt	opt	opt
P.I.D	opt	opt	opt	opt	opt	opt	opt	opt	opt	opt	opt

Exploded Drawing

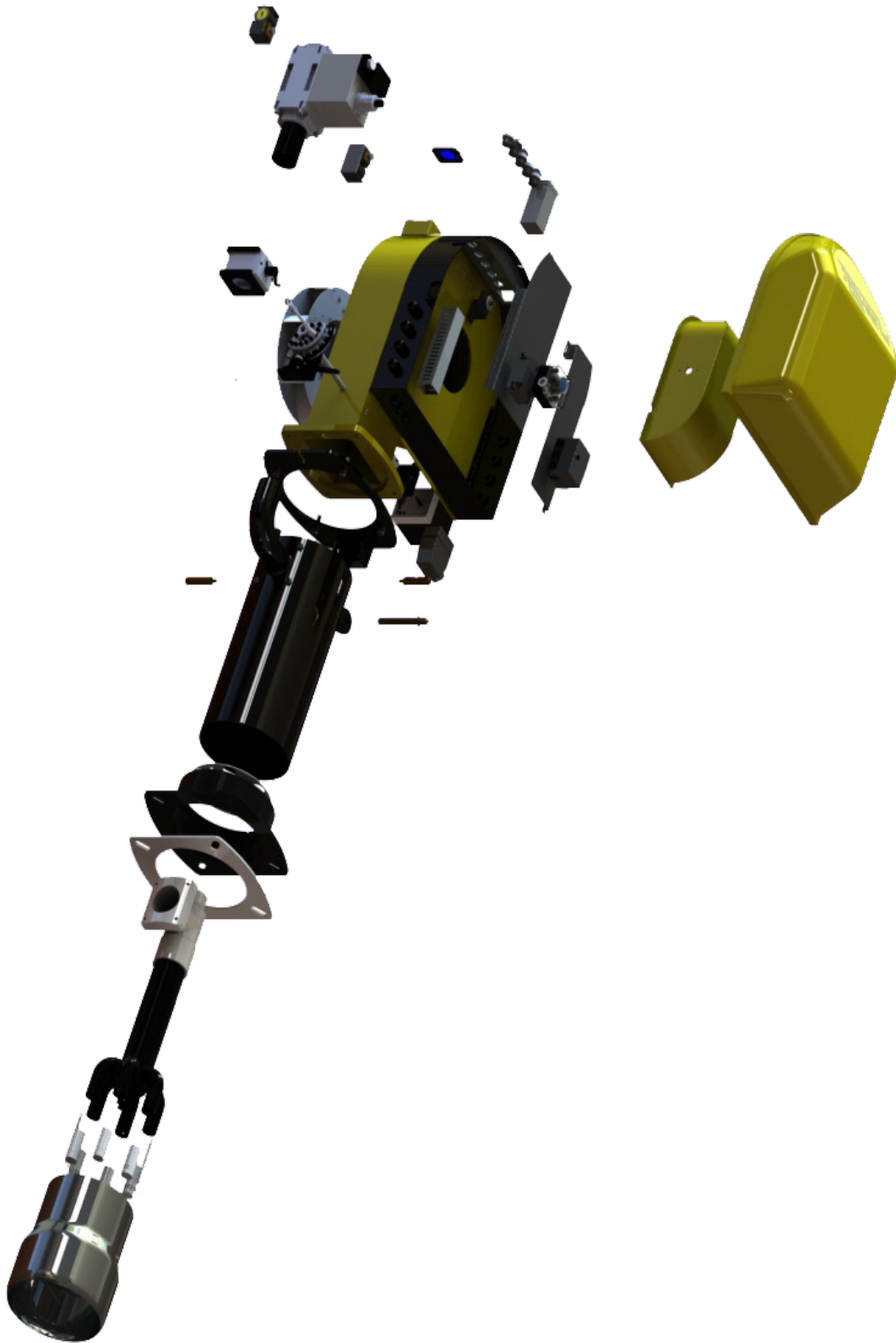

**A Leading
Manufacturer
of Innovative
Combustion Solutions**
Enginy 6 Nave 3
08840 Viladecans
Spain
Teléfono 937060052
carlos@flamtec.es
www.flamtec.es

FLAMTEC